

Environmentally Friendly Solutions for Railway Systems

Takenori Wajima
Yasushi Nakamura

OVERVIEW: As environmental issues become more and more global, the role of railways as a means of transport is gaining fresh attention. In the railway field, while safer and more stable transport is accomplished by using advanced electronics technologies, it is also becoming important to develop technologies with even more consideration for the environment. Hitachi, Ltd. is presently promoting development of energy-saving railway systems using lithium-ion rechargeable batteries — such as fitting hybrid drive systems and regenerative-power-absorption equipment using batteries in railway carriages — and advancing technical development that will contribute to expansion of railway systems.

INTRODUCTION

At present, measures to combat fossil-fuel depletion and temperature rises are being called for on a global scale, and reduction of environmental impact — that is, reduction of energy consumption in total (i.e. energy consumed not just during vehicle operation but also during vehicle manufacturing, maintenance, and disposal) and reduction of CO₂ (carbon-dioxide) emission — is demanded.

Under Hitachi’s basic philosophy of reducing global environmental impact, responding to those demands, Hitachi, Ltd. has developed a new technology that applies lithium-ion rechargeable batteries in railway vehicles. As regards railway vehicles, a hybrid drive system has been developed in collaboration with the East Japan Railway Company

(hereafter, JR East), and it has started operation in a world’s first commercial hybrid train. Moreover, as for the system for transformation of electrical power, a “regenerative-power absorption equipment using batteries” was developed. The equipment is presently running smoothly at the delivery site.

The rest of this report presents an overview of Hitachi’s solutions for reducing environmental load of railway systems (see Fig. 1).

TREND TOWARDS RECHARGEABLE-BATTERY HYBRID SYSTEMS

Background to Development of Hybrid Drive Systems

In recent years, in union with energy issues (such as depletion of reserves of fossil fuels), environmental

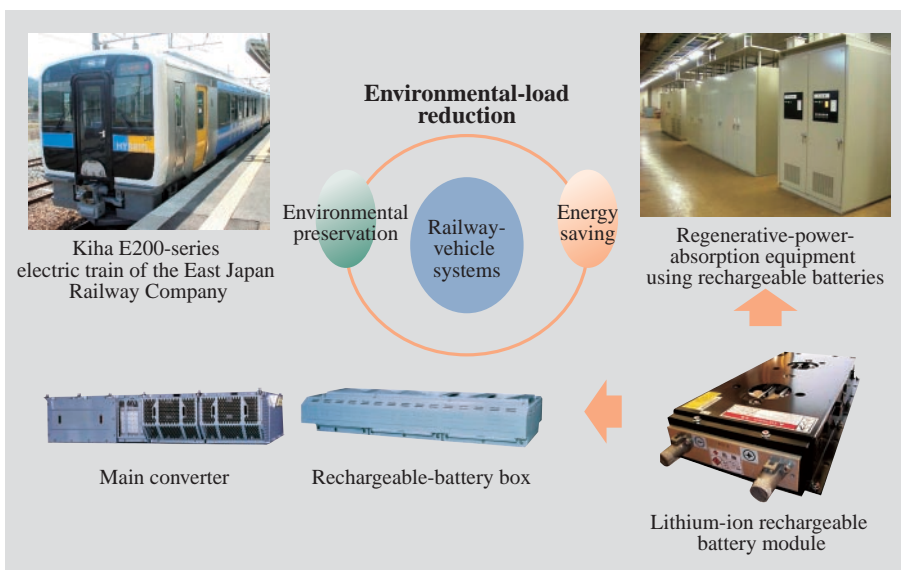

Fig. 1—Hybrid Drive Systems Applying Lithium-ion Rechargeable Batteries and Regenerative-power-absorption Equipment Using Rechargeable Batteries. External appearances of a train fitted with a hybrid drive system (which is the first in the world to be applied in a commercial train) and regenerative-power-absorption equipment using rechargeable batteries (which has started operation) are shown.

issues (such as atmospheric pollution by exhaust gases generated by various power sources and global warming by CO₂) are creating considerable concern. Under these circumstances, all car manufacturers are continuing to improve environmental performance of internal-combustion engines while developing “clean” engine systems to replace them.

In the meantime, as regards the railway field, combustion-engine trains running in non-electrified-track zones are powered by a direct-drive system with diesel engines, so the regenerative braking used in electric trains has not been applied. By enabling regenerative braking energy to be absorbed, a hybrid drive system can cut fuel-consumption costs while reducing harmful emission products.

Application Expansion of Rechargeable-battery Technology

As regards railway vehicles, to make sure the running performance is the same when a train is either running forwards or backwards, a hybrid system — based on the main conversion equipment that has compiled a good record fitted in standard JR East trains — that does not require reversing gear is adopted, and careful consideration was given to reduction of maintenance work through sharing of key components.

Furthermore, to inherit the good acceleration and deceleration performance of electric trains, the lithium-ion batteries used for hybrid cars (which combine high energy density and high power density) are adopted. In addition, as our next development, a fuel-cell train, in which the engine has been converted to a fuel-cell system, is presently undergoing trials. From now onwards, while expanding the commercialization of the hybrid drive system, we will continue to develop next-generation train systems that gain previously unavailable added value through application of rechargeable-battery systems.

HYBRID DRIVE SYSTEM OF KIIHA E200

Configuration of Hybrid Drive System

On implementing the hybrid drive system in a commercial train, it was necessary to ensure passenger facilities and take countermeasures against transit problems. In regard to the hybrid drive system for the Kiha E200, equipment compactization and system duplication were therefore implemented (see Fig. 2).

The main structural components of the hybrid drive system are summarized below.

(1) Main converter

The main converter is composed of three circuits:

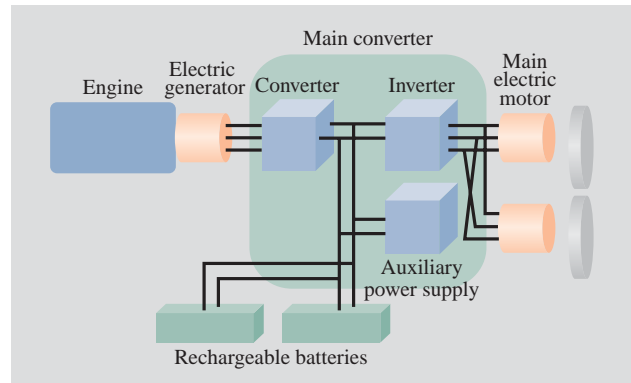

Fig. 2—Overview of Hybrid Drive System for Kiha E200 Series. Hybrid integrated control is performed by the main converter, and energy saving is achieved by the energy-management controller.

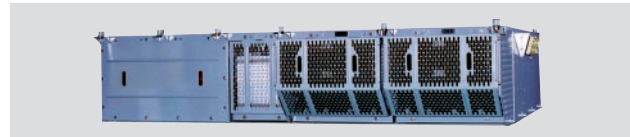

Fig. 3—External Appearance of Main Converter. The converter equipment, inverter equipment, and SIV (static inverter) are combined in a single, compact equipment.



Fig. 4—External Appearance of Battery Box. Fitted on the roof of the train carriages, the battery box is fitted with heat-shield panels to stop heating of the equipment inside it by direct sunlight.

an inverter circuit for driving an induction motor, a converter circuit for controlling generated output from a generator, and an auxiliary-power-source circuit for supplying power to air-conditioners, etc. (see Fig. 3).

(2) Rechargeable-battery box

As for the rechargeable-battery box, each box holds a group of eight lithium-ion rechargeable-battery modules, and two boxes are mounted on the roof of each carriage.

Line breakers, configured in groups of two, for throwing open failed groups during malfunctions are also installed (see Fig. 4).

(3) Main electric motor

With the standard three-phase induction motor used on, for example, JR East’s Yamanote Line in Tokyo as a base, the circuits of the main electric motor were redesigned.

(4) Generator

Based on that of the standard three-phase induction motor mentioned above, an aluminum rotor was adopted for noise reduction purposes. What's more, for the connection with the engine-output shaft, a direct drive system was chosen in consideration of making equipment as compact as possible.

Control of Hybrid Drive System

(1) System integrated control

Electrical power in each system component is monitored, the charge amount in the batteries is checked, and commands are sent to each control equipment in response to the determined status. Moreover, protection coordination during malfunctions is performed.

(2) Energy-management control

By controlling generation of electrical power by the engine in accordance with train speed and amount of stored charge in the batteries, an adequate amount of stored power can be maintained, and good running performance can be assured. To put that concretely, engine-generated power is controlled in the following manner.

- (a) While stopped: engine is stopped to cut noise pollution and improve fuel economy.
- (b) On leaving the station: battery power only is used to power the train up to 30 km/h.
- (c) During running: output power from the engines is supplemented by the batteries.
- (d) During regenerative braking: the engines are stopped, and regenerative power is stored in the batteries.
- (e) During slowing down (by braking): when the SOC (state of charge) of the batteries reaches the

charge limit, regenerative power is absorbed by the engine brakes, thereby preventing overcharging.

(3) Gradient forecast control

Energy-management control carries out gradient forecasting for efficiently utilizing potential energy (and thus improve fuel efficiency). This function recognizes the location of the train and manages energy in accordance with uphill gradients, flat track sections, and downhill gradients.

(a) Uphill gradients and flat track sections: under the assumption that the SOC (i.e. a certain amount of charge) at which discharge starts is lower than that for the "NE (new energy) train," the charge-and-discharge regions are being expanded.

(b) Downhill gradients: when the train is coasting or being powered, stored energy is given preference and used; on the other hand, when the train is braking and being slowed down, more charging is done and energy recovery rate is increased.

DEVELOPMENT OF REGENERATIVE-POWER-ABSORPTION EQUIPMENT USING BATTERIES

Hitachi has been developing regenerative inverters and regenerative power-absorption devices using resistors — as measures against regeneration lapses — since 1985, and deployed these systems in traction substations. However, each of these devices has particular strong points and weak points, and we have developed a regenerative-power-absorption equipment using rechargeable batteries — which incorporates both strong points and brings the advantage of energy saving (see Table 1).

As application effects of this equipment, preventative

TABLE 1. Comparison of Regenerative Systems

Regenerative-power absorption equipment using batteries is equipped with the advantages of a regenerative inverter and a regenerative-power absorption equipment using resistors; consequently, its energy-saving effect is large.

No.	Item	Regenerative inverter	Regenerative-power-absorption equipment using resistors	Regenerative-power absorption equipment using batteries (developed in the current work)
1	Regenerative system (pros and cons of using regenerative power)	Regenerative power is applied for collateral load of AC systems, and it can be returned to power companies.	Regenerative power is consumed as heat in the resistance unit. Regenerative power cannot be used.	Regenerative power can be stored in the batteries. The stored power can be used as traction power.
2	Pros and cons of application to voltage-drop countermeasures	(Not applicable)	(Not applicable)	(Possible) Stored power is supplied as traction power.
3	With or without constraints at installation location	(With) Transformer substation fitted with auxiliary equipment	(Without) Installation possible at many places where regeneration lapses are big.	(Without) Installation possible at places where regeneration lapses are big and voltage-drops occur
4	Necessity of ancillary equipment	(Necessary) • Inverter transformer • Higher-harmonic filter • Phase-advance capacitor	(Unnecessary)	(Unnecessary)
5	Degree of energy-saving contribution	• Regenerative electrical power can be effectively applied for ancillary load. • Equipment load is comparatively big. • Energy-saving effect	• Regenerative power is consumed as heat. • No energy-saving effect	• Regenerative power is used as power to run the train. • Big energy-saving effect

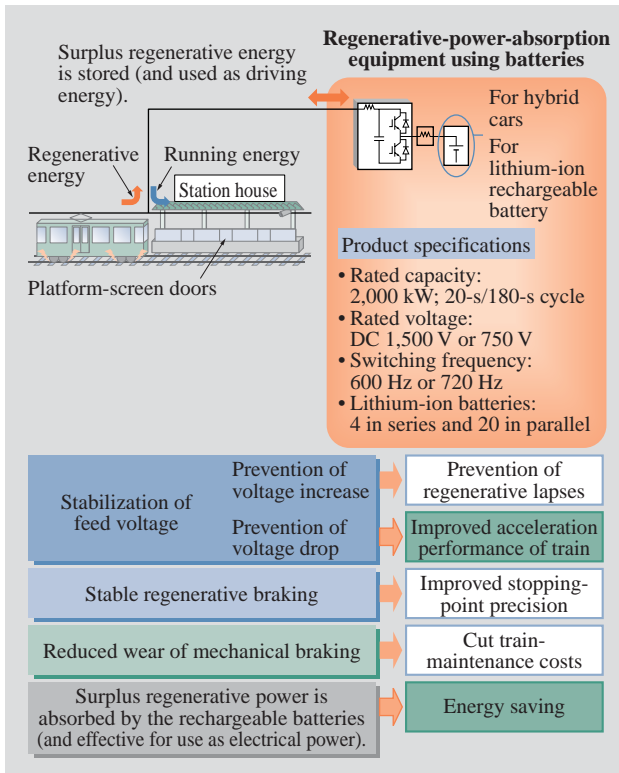

Fig. 5—Overview of Regenerative-power-absorption Equipment Using Batteries.

Application effects such as measures for preventing regenerative loss (by stabilizing feed voltage) and voltage drop are gained with this equipment.

measures against regeneration lapses (by means of stabilization of feeder voltage) and voltage sag (and improve train acceleration performance) were achieved. Moreover, benefits such as regenerative-braking power is stabilized by stabilizing the feed voltage, precision of train stopping position is improved, and reduction of brake wear of the mechanical brake shoe is anticipated. Some effects of applying the regenerative-power-absorption equipment using rechargeable batteries are summarized in Fig. 5.

PRODUCT SPECIFICATIONS AND APPLICATION

Product Specification

The product specifications of the regenerative-power-absorption equipment using rechargeable batteries launched commercially are listed below.

- (1) Rated capacity: 2,000/1,000 kW (180-s cycle for 20-s operation)
- (2) Rated voltage: DC 1,500/750 V (rated capacity in the case of DC 750 V is 1,000 kW)
- (3) Switching frequency: 600 Hz/720 Hz
- (4) Lithium-ion rechargeable-battery module

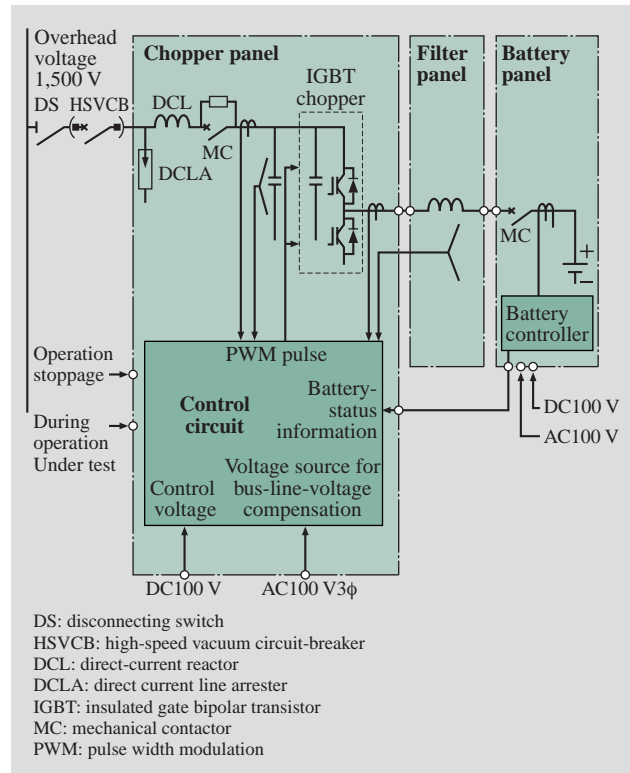

Fig. 6—Overview of Circuitry of Regenerative-power-absorption Equipment Using Batteries. Circuit configuration of commercial equipment is shown.

configuration: four in series and 20 in parallel (2,000 kW)

Circuit Configuration

The regenerative-power-absorption equipment using rechargeable batteries is composed of a circuit split into three blocks, namely, a chopper panel, a filter panel, and a battery panel (see Fig. 6). Moreover, even if one system fails, the train can be kept running by the remaining operational system. As for chopper frequency, 600 Hz in the same 50-Hz region as the ripple frequency of a 12-pulse rectifier (which also has a good record in the case of regenerative-power absorption equipment using resistors) and 720 Hz in the 60-Hz region are standardized. As for the converter, an IGBT (insulated gate bipolar transistor) element (3,300 V/1,200 A) is used, and ripple current to the feeder lines and batteries is mitigated by implementing the bidirectional chopper as a four-multiplex configuration. The storage cells are standardized as lithium-ion rechargeable-battery modules containing four cells in series and 20 cells in parallel.

As for the operational control of the chopper panel,

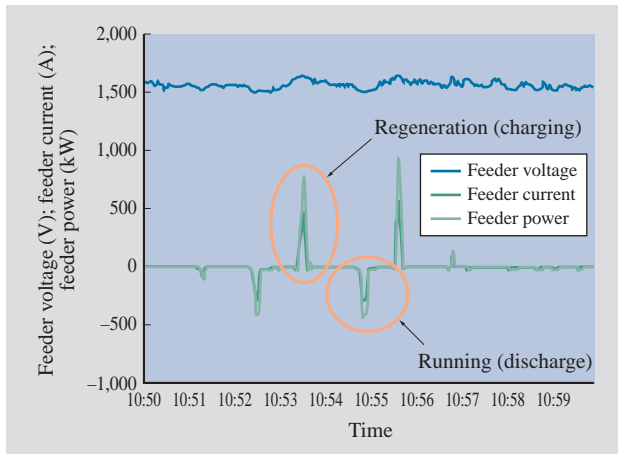

Fig. 7—One-second Sampling Graph Obtained by On-site Measurement.

Charge and discharge performance is maintained at the initial level. Feeder voltage absorbs regenerative power and is stabilized. Batteries discharge when train is powered, and drop of feeder voltage is suppressed.

feed-line-voltage control, for controlling feed-line voltage within the prescribed range by charge and discharge of the lithium-ion rechargeable batteries, and charging-rate control, which keeps down charging rate for the next charge (by regenerative-power absorption) during standby, are built in; as a result, constant control of feed voltage as well as high-efficiency utilization and long life of the rechargeable batteries are simultaneously accomplished.

Product Commercialization

This regenerative-power-absorption equipment using rechargeable batteries is effective in either the case that it is installed in a transformer substation or in place where the voltage drop between line terminals is large or between transformer substations with large voltage drop. Examples of feeder voltage, current, and power during actual operation are plotted in Fig. 7. It is clear from this graph that drop in feeder voltage is controlled by stable regenerative power absorption and

stored-power discharge. Moreover, in the case that the equipment is installed in a substation, by using one bank of the two conventionally installed rectifier units for this regenerative-power-absorption equipment, it is possible to supplement the rectifier unit and absorb regenerative power.

CONCLUSIONS

This report overviewed Hitachi's solutions concerning reduction of environmental load of railway systems. In response to social needs concerning the worldwide problem of reducing emission gases that cause global warming, Hitachi, Ltd. will continue from now onwards to vigorously promote research and development on new railway systems focused on further improving existing technologies and in line with various changes in speed.

REFERENCES

- (1) T. Kaneko et al., "Easy Maintenance and Environmentally-friendly Train Traction Systems," *Hitachi Review* **53**, pp. 15–19 (2004).
- (2) M. Shimada et al., "Energy Management Control of a Fuel-cell Train," Annual Conference of The Institute of Electrical Engineers of Japan, Industry Applications Society (Aug. 2007) in Japanese.
- (3) H. Takahashi et al., "Effective Utilization of Regenerative Power," *Railway & Electrical Engineering* (Jun. 2005) in Japanese.
- (4) T. Ito et al., "Development of Lithium-ion Regenerative-power-absorption Equipment Using Rechargeable Batteries," The Institute of Electrical Engineers of Japan, Transportation and Electric Train Workshop (Sep. 2005) in Japanese.
- (5) H. Takahashi et al., "Establishment of an Effective Utilization Method for Regenerative Power," 42nd Cybernetics Symposium, p. 606 (Nov. 2005) in Japanese.
- (6) M. Ito et al., "Overview of Field Trials of Regenerative-power-absorption Equipment Using Rechargeable Batteries," *Railway & Electrical Engineering* (Jan. 2007) in Japanese.
- (7) H. Takahashi et al., "Establishment of an Effective Utilization Method for Regenerative Power," *Rolling Stock and Technology* (Feb. 2007) in Japanese.

ABOUT THE AUTHORS



Takenori Wajima

Joined Hitachi, Ltd. in 1980, and now works at the Rolling Stock Engineering Department, the Rolling Stock Systems Division, the Transportation Systems, the Industrial Systems. He is currently engaged in the engineering of rolling stock systems. Mr. Wajima is a member of The Institute of Electrical Engineers of Japan (IEEJ).



Yasushi Nakamura

Joined Hitachi, Ltd. in 1990, and now works at the Transportation Substation Systems Department, the Transportation Systems Division, the Transportation Systems, the Industrial Systems. He is currently engaged in the engineering of traction-power-supply systems.